



Wave Solder Infeed J219-02

Transfers PCBs into a soldering machine • Adjustable infeed speed • Adjustable infeed angle and track height • Easy maintenance



Rohwedder
Excellence in Automation

JOT AUTOMATION LTD.
WWW.JOTAUTOMATION.COM



Please see www.jotautomation.com for country by country sales and service contact details.

Wave Solder Infeed J219-02

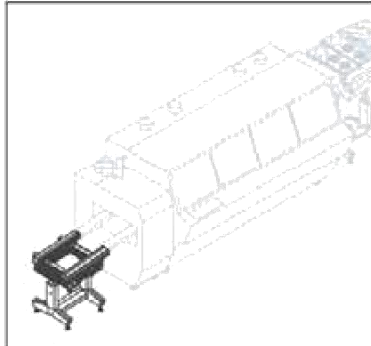

Wave Solder Infeed J219-02

Standard Features

- Steel frame construction
- Automatic indexing and manual inspection modes
- PLC controller
- Start, Stop, Reset, Emergency Stop, Inspection and Send switches
- 2 standard frame lengths; 500, 700 mm (19.6", 27.5")
- SMEMA electrical interface
- ESD-safe design
- CE-safety compliant
- Lead free process compatible

Technical Characteristics

- Fixed edge 165 mm (6.5") from front
- Track height 750 - 1000 mm (29.5" - 39.4"), adjustable
- Track width W, adjustment by hand crank
- Adjustable incline angle 2° - 9°
- Speed control 1 - 3 m/min (10 - 20 fpm)
- Available segment lengths 250 - 700 mm (9.9" - 27.6")
- 9 mm flatbelt with 3 (0.1") carrying egde
- Weight; length 500 mm (19.7") 60 kg (132 lbs), length 700 mm (27.6") 75 kg (165 lbs)

K

Installation Requirements

- Power supply 220 - 240 VAC / 50 Hz / 1 A or 110 - 120 VAC / 60 Hz / 2 A

Options

- Manual tool, Motorized or line width adjustment
- Speed control 2 - 6 m/min (13 - 40 fpm)

Board Specifications

- JOT Board Specification 470

